



DIVE-TURBINE

compact – efficient – reliable

The compact turbine system for highest demands in terms of efficiency and ecology in hydropower





DIVE-TURBINE

compact – efficient – reliable



Milestones	
2006	Commissioning DIVE-Turbine prototype
2007	First customer order from Austria
2011	DIVE-Turbine in Chile
2012	First DIVE-Turbine in a pressure chamber
2014	Three DIVE-Turbines in the megawatt category
2015	DIVE-Turbine in Croatia
2017	45 DIVE-Turbines in 9 countries

Turbine parameters	
Nominal power	30 kW - 4000 kW
Head	2.00 m - 60.00 m or 6 ½ ft - 196.85 ft
Discharge	0.60 m³/s - 40.00 m³/s or 20 cfs - 1,400 cfs
Runner diameter	0.50 m - 3.50 m or 1.60 ft - 11.50 ft
Diameter incl. guide vanes	1.00 m - 6.00 m or 3.30 ft - 19.70 ft
Height incl. generator	0.80 m - 5.00 m or 2.60 ft - 16.40 ft
Weight incl. generator	1.20 t - 40.00 t

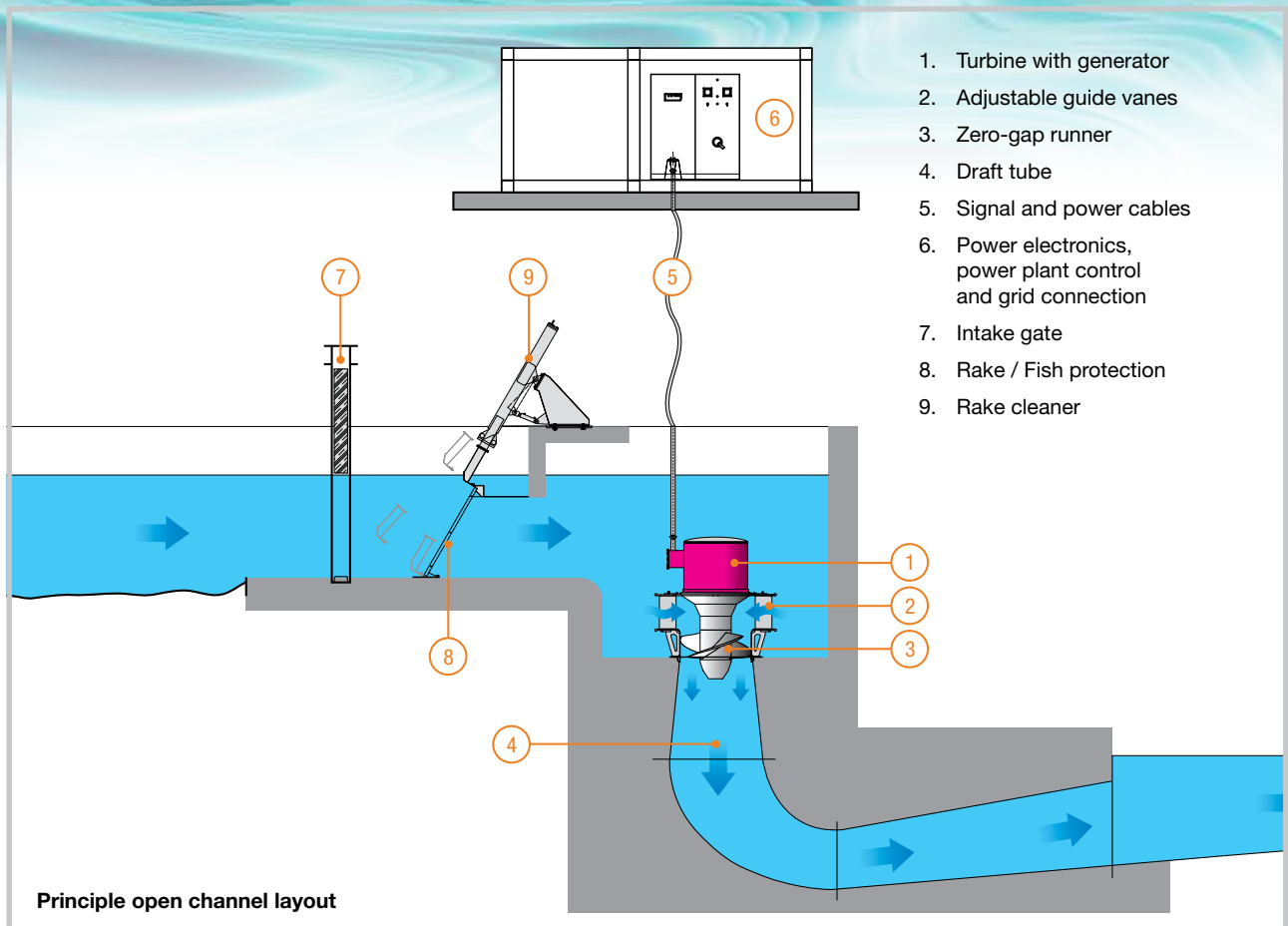

1. Turbine with generator
2. Adjustable guide vanes
3. Zero-gap runner
4. Draft tube
5. Signal and power cables
6. Power electronics, power plant control and grid connection
7. Intake gate
8. Rake / Fish protection
9. Rake cleaner

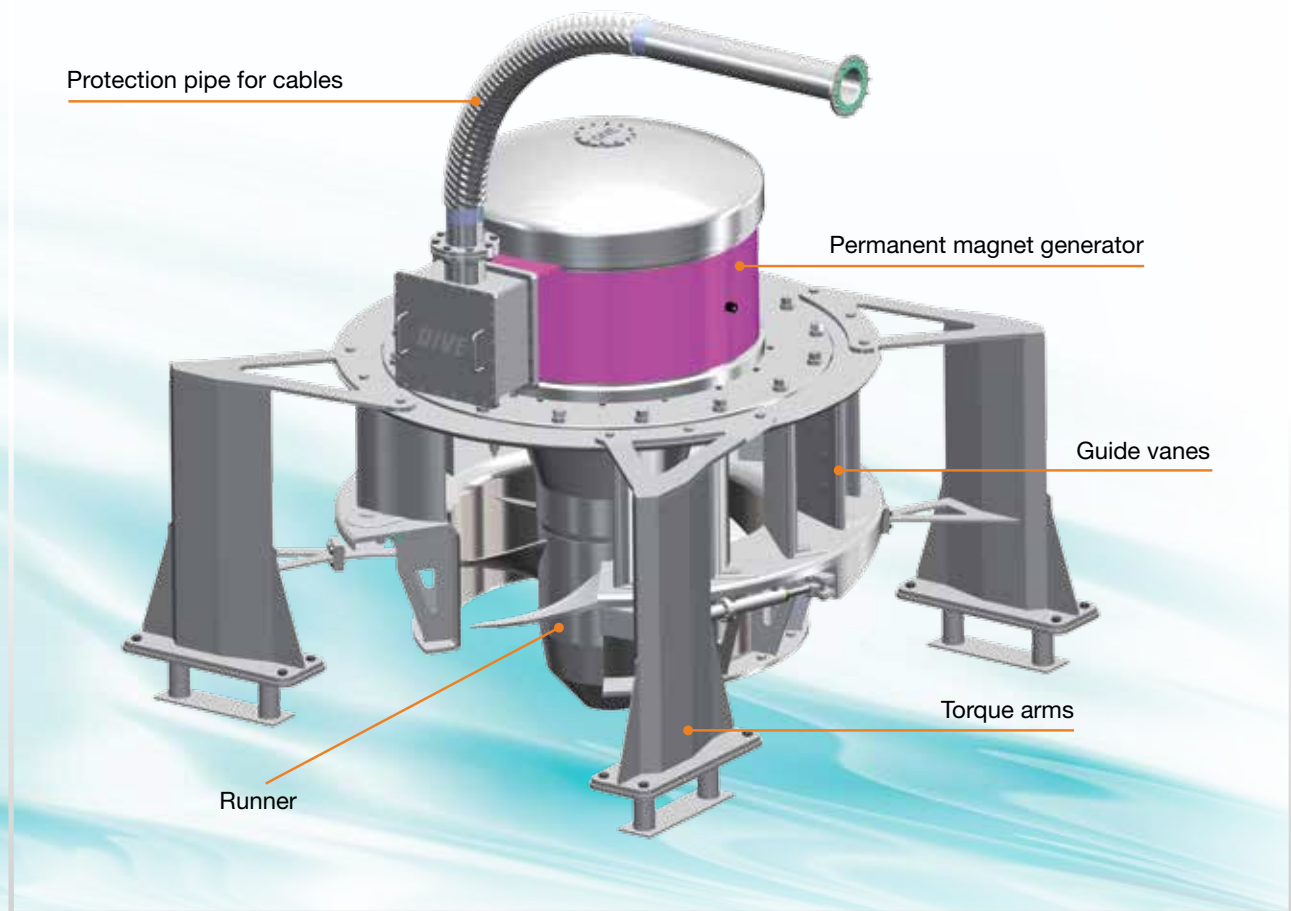

Characteristics	Technical benefits	Benefits for operator and owner
Compact turbine and generator unit completely submerged	<ul style="list-style-type: none"> + No turbine house required + Minimum cost of civil works + Save operation in flood-areas 	Reduced investment
Direct-drive, free of mechanical transmission	<ul style="list-style-type: none"> + Minimum noise and vibration + Free from maintenance and free from wear and tear + No gearbox or belt-drive losses 	Hydropower in residential areas
Single bearing unit for turbine and generator	<ul style="list-style-type: none"> + Permanent lubrication of bearing unit in oil bath + Leakage of lubricants (oil) impossible + No danger in cases of runaway speed and grid interruption 	Minimum operational cost and risk
Wear and tear free sealing system	<ul style="list-style-type: none"> + No necessity of a costly sealing system + Free from maintenance and free from wear and tear + Save operation in saline and dirty water 	Maximum technical availability and no risk at flood situations
Fixed runner blades	<ul style="list-style-type: none"> + No maintenance and wear-intense pitching of the runner + Runner design optimized for max. efficiency + Zero-gap and fish friendly runner 	Better chance of gaining approval due to a fish friendly power plant
Double regulation by variation of speed and pitching of the guide vanes	<ul style="list-style-type: none"> + High efficiency at part-load (reduced flow) + Fish friendly hydropower plant operation + Discharge from 10% to 100% 	High annual revenue
Components in contact with water made of stainless steel	<ul style="list-style-type: none"> + High resistance against wear and corrosion 	High durability of the main components (e.g. runner and guide vanes)

Range of application

Applications

- New hydropower plants
- Reactivation of existing hydropower plants
- Modernization and repowering of existing hydropower plants
- Integration into:
 - + existing weir structures (residual / ecological flow)
 - + existing buildings
 - + irrigation channels
 - + thermal units
 - + cooling circuits
- Fish friendly hydropower plants, e.g. shaft power plants
- Hydropower plants with open channel or pressure pipe

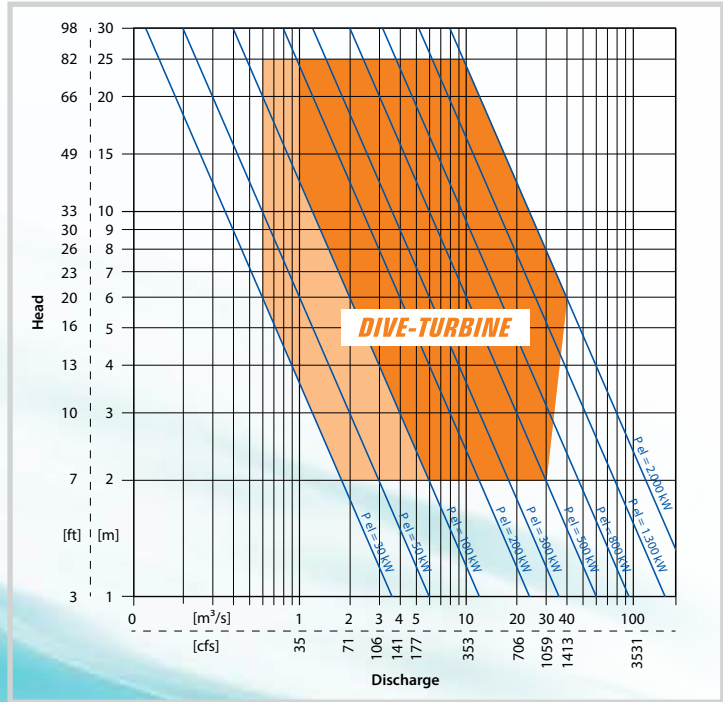

Modernization

Hydropower plant Tegernsee
Commissioning 2011



Before modernization



After modernization

Installation example pressure pipe



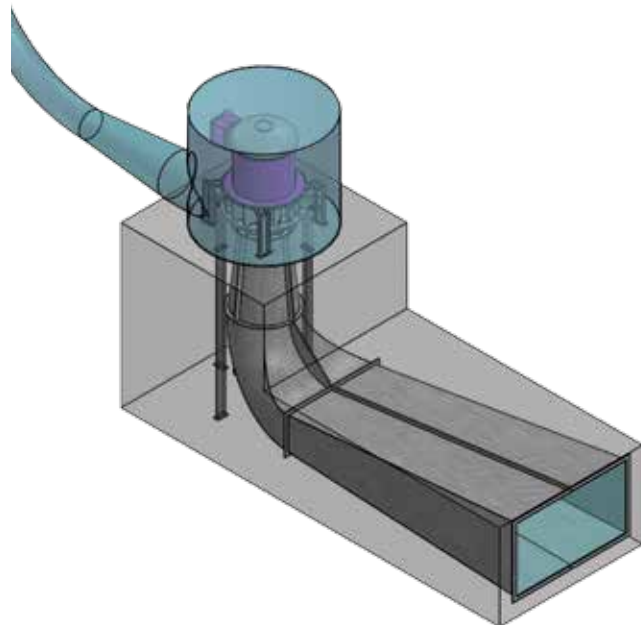

Hydropower plant Dabrova (Croatia)
Commissioning 2016

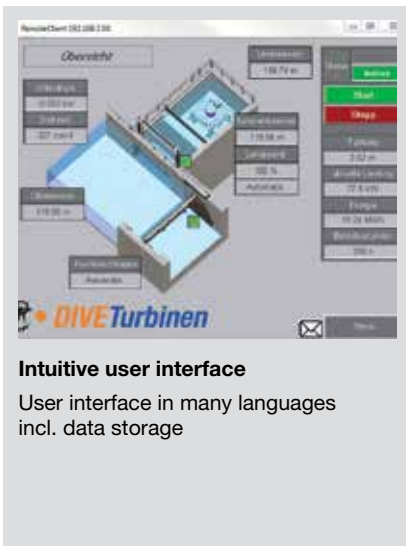
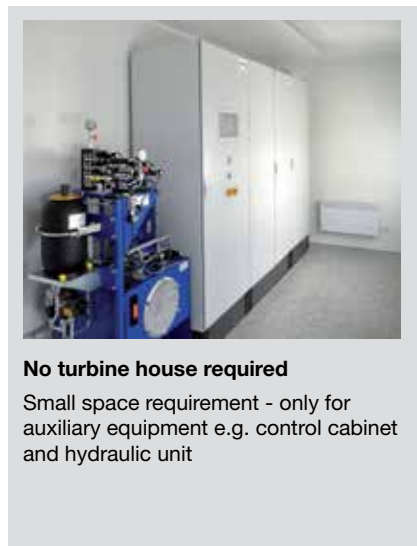
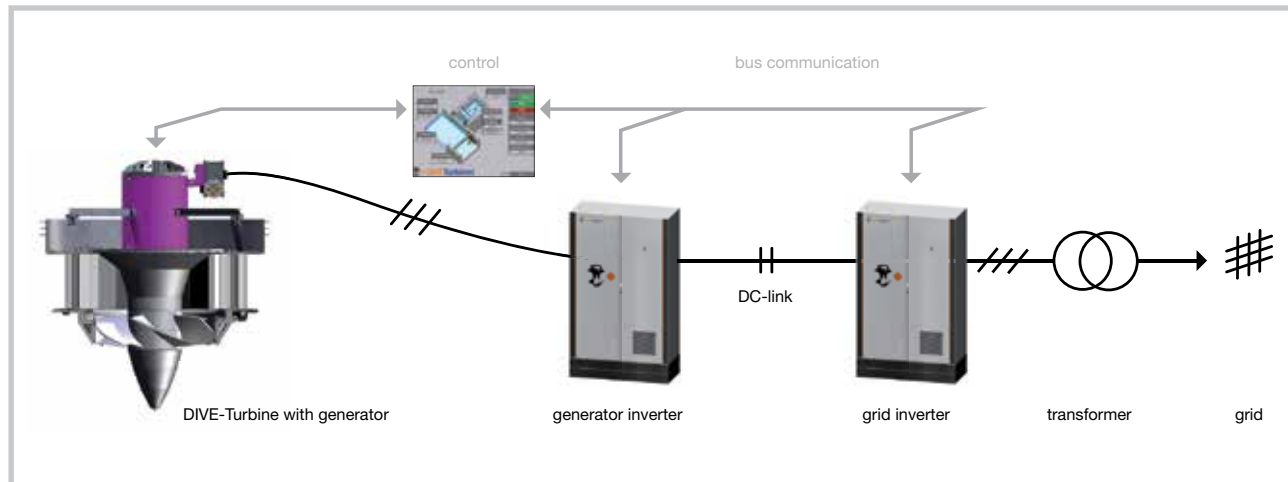



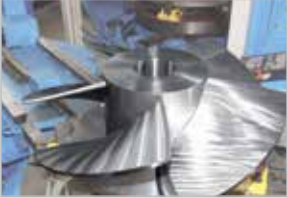



Characteristics	Benefits
Speed variable operation with frequency converters (for power plants with only one turbine and / or variable discharge)	<ul style="list-style-type: none"> + Dynamic adaptation to the specifications of grid-operators from $\cos \varphi$ 0.85 to $\cos \varphi$ 1 + Feed-in according to the country specific grid code + Optimized power plant operation + High efficiency at the whole range of operation
Fixed speed operation with direct grid connection (for power plants with multiple turbines and / or constant discharge)	<ul style="list-style-type: none"> + Maximum output at 80% to 100% discharge + Very robust solution + Cost optimization
Customized coding of control system	<ul style="list-style-type: none"> + User-friendly operation + Support of commissioning on site
Fully automatic operation	<ul style="list-style-type: none"> + Support of the power plant operation via remote control and remote service + Minimum operating expense

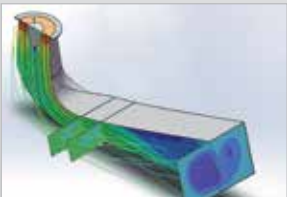

Scope and service

 <p>Engineering and design</p>	 <p>Manufacturing</p>	 <p>Assembly and quality control</p>
 <p>Shipment and transport</p>	 <p>Installation</p>	 <p>Commissioning</p>

Optional services

 <p>Consulting during permission process</p>	 <p>Funding concepts</p>	 <p>Flow simulation and hydraulic optimization</p>
 <p>Power plant design</p>	 <p>Fish friendly power plants</p>	 <p>Extension of warranty and service up to 20 years</p>

Exclusive partner for USA and Canada:



DIVE Turbinen GmbH & Co. KG

Am Grundlosen Brunnen 2
63916 Amorbach
Germany

phone: +49 9373.9749-42

fax: +49 9373.9749-49

email: info@dive-turbine.com

web: www.dive-turbine.com



Bridge Executive Energy Solutions Ltd.

30 Helena Court
Fredericton, NB, E3B OE2
Canada

Kenneth Cripps, CPA, CGA, CMA - CEO

phone: +1 506.259 4944

email: ken.cripps@bridge-executive.com